

| ITEM | QTY | TIME | BY |
|------|-----|------|----|
| | | | |
| | | | |
| | | | |

- NOTE:-
1. MANUFACTURE TO BE IN ACCORDANCE WITH AS-1554.
 2. MANUFACTURE TO BE SQUARE AND FREE FROM DISTORTION WITHIN TOLERANCE.
 3. WELDING TO BE CONTINUOUS AND FREE FROM HOLES AND POROSITY.
 4. ALL EXTERNAL AND INTERNAL WELDS TO BE DRESSED.
 5. ALL WELDS TO BE FREE FROM SPATTER.
 6. REMOVE ALL SHARP EDGES, CORNERS AND BURRS.
 7. NITROGEN BLANKET GAS TO BE USED ON LASER PROCESS.
 8. SCRACHED AND COUGED SURFACES WILL NOT BE ACCEPTED.

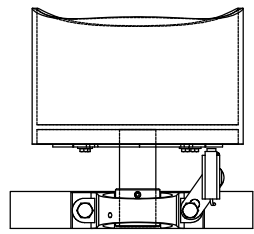

PULLEY DIAMETER 85mm

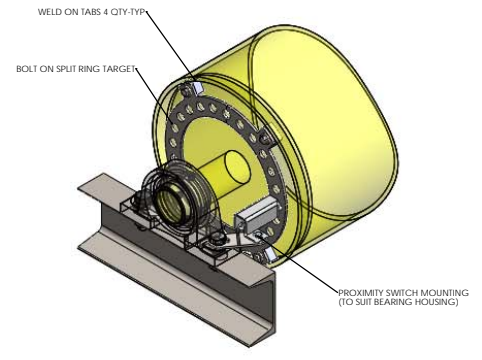
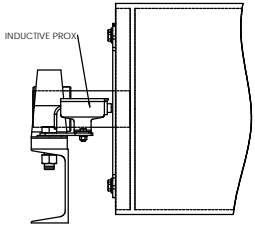
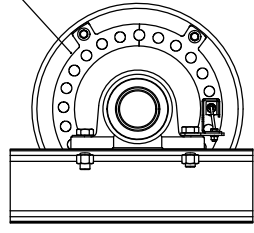

DRAWN BY: A. WINDYBUSH & B. BELL
 CHECKED BY: G. BELL

| UNLESS OTHERWISE STATED | | UNIT | SYMBOL |
|-------------------------|-----------------|----------------|--------|
| LENGTH | mm | m | M |
| AREA | mm ² | m ² | M |
| VOLUME | mm ³ | m ³ | M |
| WEIGHT | kg | t | T |
| TEMPERATURE | °C | °F | F |
| ANGLE | ° | ' | ' |
| RADIUS | R | | |
| DIAMETER | Ø | | |

| | | | |
|--|--|--|----------------------------|
| | WEB-TECH AUSTRALIA PTY. LTD. <small>1/100 WINDYBUSH ROAD, WINDYBUSH NSW 2150 PO BOX 400 WINDYBUSH NSW 2150 PHONE: (02) 9611 2000 FAX: (02) 9611 2001</small> | | DRAWING NO. 5012 |
| | CONVEYOR PROXIMITY SPEED SENSOR GENERAL ARRANGEMENT | | SCALE 1:1 |