



WEB-TECH

Model 200 Weight and Level Controller

The Model 200 is a microprocessor based level and weight indicator. Level data is provided by means of a local analogue display and an isolated 4/20mA current source an RS 485 port is also available for digital data transmission. The Model 200 can accept the output from 3 and 4 wire style load cells. It is an ideal instrument for use with "bolt on" and "pass through" type gauges commonly used to instrument existing tanks, silos etc.

- ◆ Level control using direct support (load cells) or stress measurement (bolt on/pass through) technology, are industries preferred methods, for the following:-
- ◆ No inaccuracies caused by material profile.
- ◆ Weighing provides continuous level control.
- ◆ No performance, degradation caused by material build up on sensors. Sensor are fitted outside the tank and therefore not subject to hostile environments often found inside tanks and silos especially when being filled.
- ◆ Dust in the tank/silos atmosphere cannot blind the controller whilst filling.
- ◆ Load cells etc are passive devices which do not emit annoying sound waves, radio waves or laser light and are therefore more acceptable to production workers and maintenance staff.



The Model 200 comes with standard features that other manufacturers call options. The combination of a 20 bit Sigma Delta Analogue to Digital converter and selectable amplifier gain, enables the instrument to accommodate a wide range of input signals. These features together with the ability to accept both full - bridge and half bridge type load cells and strain gauges, make the Model 200 a truly versatile device.

The built in functions such as zeroing, calibrating, and the programming of set points are simply accessed and performed through a built in four key, keypad.

The Model 200 level controller is a "state of the art" device, utilising an embedded Motorola HC11 microprocessor as the main processing element.

The microprocessor is watchdog equipped. Providing the user with "get up and go" after a program disturbance.

The power supply is rugged and uncomplicated and fitted with line filters. For applications where the mains power is exceptionally noisy Web-Tech can optionally supply proprietary line filters.

Augmenting the built in electronic hardness of the electronics, is the provision of an IP65 / NEMA 4X rated enclosure, made from moulded fibreglass polyester and incorporating patented quick release latches and piano style hinges.

Moulded fibreglass polyester has outstanding chemical and temperature resistance and exhibits excellent weatherability and physical properties. Oil resistant "O" ring gasket with tongue and groove construction combine to produce a consistently repeatable seal.

An optically isolated, parallel analogue to digital converter provides

a full 12bit output to the current source. The current loop output is fully isolated and internally generated. The signal can be driven into a maximum of 800 Ohms. A light emitting diode fitted to the main processor PCB provides visual indication of current loop failure. Signal dampening is to provide for noisy bins and tanks. A systems status relay has been provided, allowing PLC etc to poll status of the instrument. All field programmed parameters are stored in non volatile memory, so power outs do not require the user to re program. The Model 200 is switch selectable 120/240VAC dual voltage operation. High and low relay outputs have been provided for those customers without access to a PLC. To negate the effects of product build up when weighing material. The Model 200 has an Autozero tracking routine.

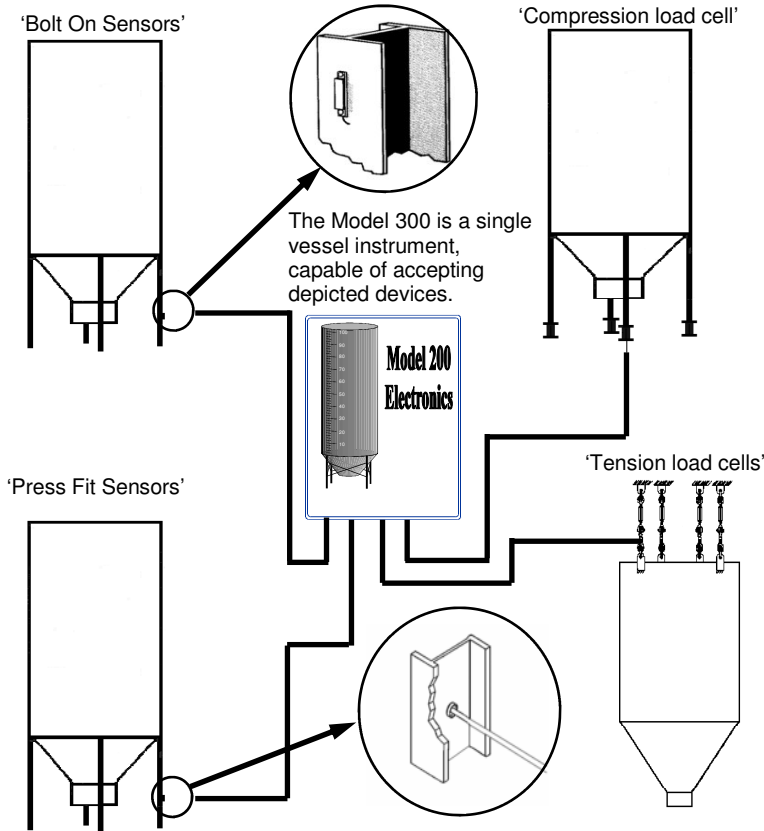
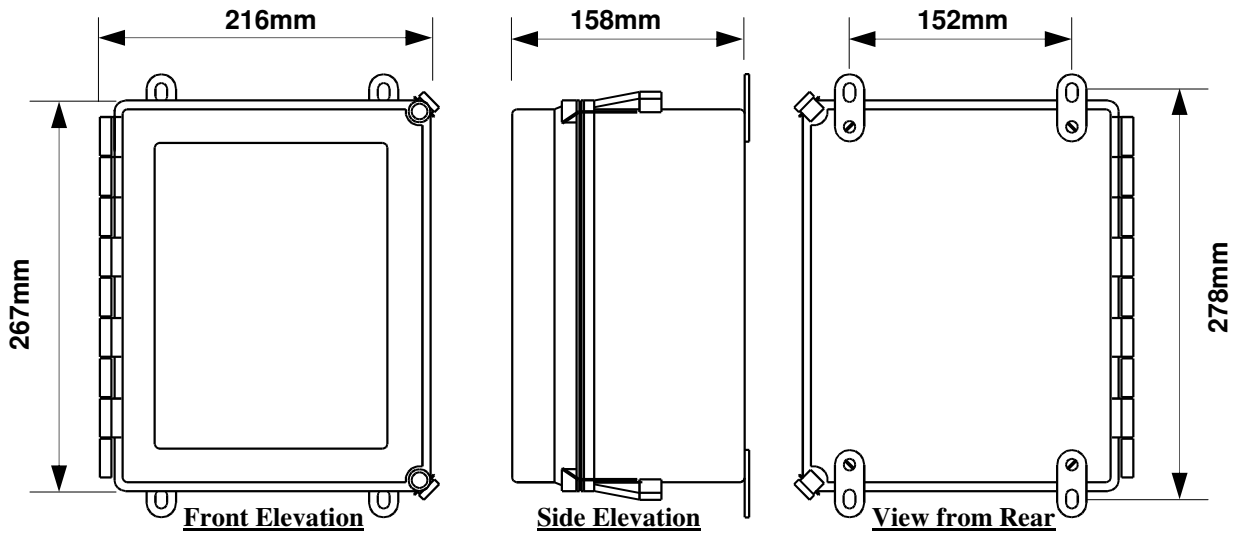

Technical Specifications:

Power Requirements Mains Supply*

240V AC +/- 10% 50-60 Hz: 117V AC +/- 10% 50-60Hz

*Mains supply voltage is switch selectable
12VDC, 24VDC & 48VDC Powered Model 100 are available. Specify at time of ordering.

Enclosure

Moulded Fibreglass reinforced Polyester, Rated IP66 or Nema 4/X

Stainless Steel Optional Supply (consult factory)

Dimensions: 267 x 216 x 158mm

Mounting: Suitable for wall mounting only

Shipping Weight: 4kg

Stainless Steel Sunshade are an optional extra.

Load Cell Excitation

Voltage:..... 12 Volts DC, fixed.

Current:.....200mA, internally limited.

Load Cell Input Range:.....0 - 1 Volt.

Resolution:..... 20 bits.

Load Cell Type: Will accept both **full-bridge** and **half-bridge** type load cells.

Display..... Analogue Meter 0-100%

Analogue Output

4-20mA Current Transmitter Fully isolated, internal loop supply, 800 ohms max loop resistance .

Setpoint Relay Outputs

Quantity: two, identical.

Programmable Range:..... 0 - 100%

Contact Rating:..... 240V AC @ 5A, resistive.

Status Relay Output

Contact rating:.....20V DC @ 0.5A, resistive.

Environmental

Temperature:.....-10°C to 50°C, when operated continuously. 0°C to 70°C, cold start.

Head Office,
WEB-TECH AUSTRALIA PTY LTD,
11 ELECTRONICS STREET,
EIGHT MILE PLAINS, 4113.
QUEENSLAND.
AUSTRALIA.

Postal Address
P.O. Box 4006
Eight Mile Plains
4113
Queensland,

TEL 07 3841 2844
FAX 07 3841 0005
International Tel +61 7 3841 2844.
International Fax+61 7 3841

Sydney Office:
Suite 9/16 Anella Avenue,
Castle Hill. NSW. 2154
Ph (02) 757 2296
Fax (02)8996585

REPRESENTED BY