



WEB-TECH

MDX Metal Detector



Web-Tech's model "MDX-1" Metal Detection provides a reliable, versatile and cost effective solution to the problem associated with tramp metal in a material stream.

The system comprises a transmitter and dual detection coil assembly, sandwiched in fibreglass. A microprocessor based electronics module combines with the coil assemblies to form a reliable and dependable system that performs where others fail .

Process trip and marker control outputs are standard.

Detection Method:

Designed for normal mining, quarrying and tertiary processing applications, the "MDX-1" utilises **dual channel pulsed eddy** current technology. This unique approach allows for a form of signature analysis to be performed on the tramp signal, thus helping to prevent "phantom" trips. To provide the highest sensitivity and still retain stability, the detector uses a very low excitation frequency to the generator coil. This method avoids much of the induced "noise" from non-metallic variations of the product stream. As metal passes through the detector coils, the eddy current losses created by the tramp metal cause the detector coil to be loaded. This dampens the oscillations of the transmitter signal. A simple voltage level detector is DC coupled to a low

pass filter and amplifier, which process the minute variations in field strength. The gain of the filter amplifier block is adjustable, and a unique offset control is provided to suppress the signal, relative to the programmed "trip" level. This allows high sensitivity to be used in the presence of normal process "noise" signals.

Precise selection of filter and coupling characteristics have provided this detector with inherently high response to tramp metal, and a corresponding high rejection of cyclic "noise".

Electronics Features

The "MDX-1" electronics is supplied in an IP66 reinforced fibreglass enclosure, and incorporates integral keypad for all programming. All information is displayed on a backlit LCD display.

Programming is in simple "English", in a menu based system. Standard features include sensitivity and offset adjustment, bar graph indication of metal signs timed output, diagnostic facilities, "coast" counter for multi trips, and "real" time history of detects trips.

Detector Coils:

Detector coils are supported by means of fibreglass support structure with "swing away" feature for oversized burden. Detector coils are fabricated to suit any conveyor width and conveyor profile.

Marker Systems.

The "MDX-1" can be supplied with optional burden marking systems including "flag" and "spray" types.



WEB-TECH

MDX Metal Detector

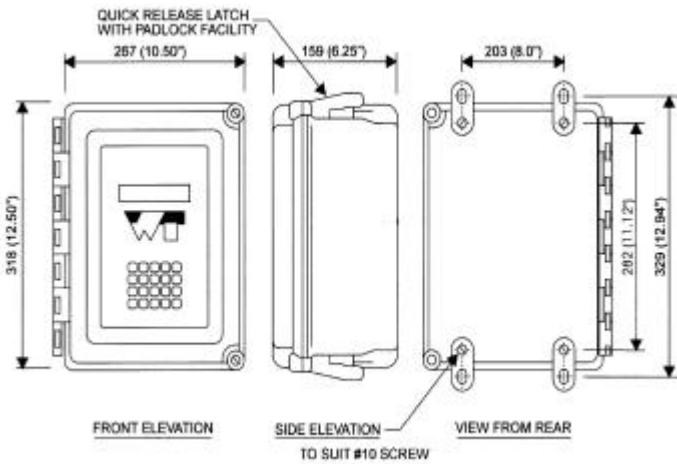

Specifications

Enclosure

Material Reinforced Fibreglass (S/Steel Optional)

Degree of protection IP 65

Dimensions (mm) 318H X 267W X 159D

Power Supply

Mains Supply 110/240VAC (Switch selectable)

Indication

Display 2 X 40 LED Backlit

LCD

Trip Indication light (Optional) (fitted to enclosure)

Inputs

Transmitter Coil

Receiver Coil

Remote Reset All optical isolated

Coil Swing Away (Optional)

Belt Splice Detector (Optional)

Outputs

Direct Relay - 2A/250 VAC

Timed Relay - 2A/250 VAC

Marker Relay - 2A/250 VAC

Sensitivity

Typically a ferrous sphere with a diameter equal to 5% of the aperture distance

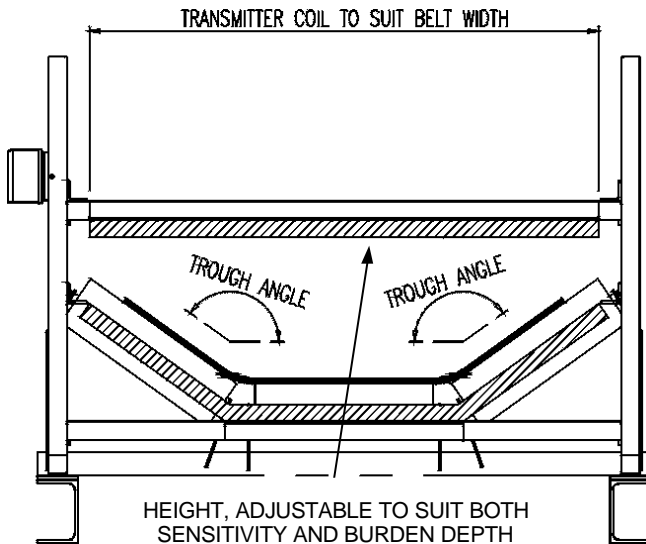

Web-Tech Australia Pty Ltd.

Head Office : Brisbane

11 Electronics Street,

Eight Mile Plains 4113,

Queensland, Australia.

Ph 07 3841 2844

Fax 07 3841 0005

International

Ph +61 7 3841 2844

Fax +61 7 3841 0005

Sydney Office

Ph 02 9899 6585

e-mail : webtech@onaustralia.com.au

Web-Page: <http://www.web-tech.com.au>

