



WEB-TECH

Masterweigh 5 Electronic Integrator

Designed for use with:-

**WEIGH BELT FEEDERS : CONVEYOR BELT SCALES
WEIGHING SCREW FEEDERS etc.**

Masterweigh 5 is a precision, second generation microprocessor based integrator. Modular in design, comprising Main Processor and Power supply boards mounted in a Nema 4 enclosure, the system is easily field serviceable. Masterweigh 5 has been designed to be used with Web-Tech's range of conveyor belt scales, weigh belt feeders and weighing screw feeders. However it is an ideal replacement for older load cell based installations, manufactured by others. Features which are considered "options" with other manufacturer's products are standard on Masterweigh 5.



Standard Features.

- ◆ Microprocessor based.
- ◆ All commands are entered via a thick film keypad.
- ◆ Simple menu driven interface.
- ◆ A 2 x 40 character LCD back lit display allows all commands to be displayed in unabbreviated English. No hieroglyphics are used.
- ◆ Local Mass Rate and Total readings, 8 digits wide.
- ◆ Remote totaliser output, selectable as either 5V DC, 28V DC or voltage free contacts.
- ◆ Optically Isolated 4-20 mA rate output, internally or externally powered.
- ◆ "System Status" alarm relay indicating "Weigher Healthy".
- ◆ Programmable Auto Zero Tracking function with high /low limits and "Out of Limit" alarm relay providing voltage free contacts.
- ◆ Automatic Zero & Span adjustments.
- ◆ All analog & digital outputs are isolated.
- ◆ Belt speed indication.
- ◆ Data security codes user enterable.

Optional Features

- ◆ Load cell lightning surge protection.
- ◆ Large graphic display. 'Active' mains noise suppression filter.
- ◆ Real-time clock, providing date and time stamped data to optional printer.
- ◆ RS 485 Serial Output.

Easy Set Up and Calibration

Masterweigh 5 has been designed to allow easy set-up and calibration. Set-up is by means of an integral twenty key keypad. Service functions can be reviewed at any time without interruption to the operation of the integrator. There are three levels of data calibration access security which are user definable and field programmable. All commands are in full English (other languages are available) and abbreviated codes are not used. Access to calibration functions is by means of a single keystroke. The simple menu structure provides prompts for technicians/operators when entering information or carrying out calibrations. Masterweigh 5 has built in linearization routines for the calibration of difficult to

handle materials, or weighframes situated in poor conveyor structures. Serial Outputs for remote Indicators/PLC/DCS are as follows: RS 232 - output for local printer: and system diagnostic aids. RS 485 (optional) - for remote calibration (useful when the electronics are sealed in explosion or dust ignition proof enclosures.)

Display

All local information, mass rate and accumulation, is displayed on a 2 x 40 character liquid crystal display. All data is displayed in English. Codes and hieroglyphics are not used therefore operators are less likely to be confused when calibrating or interrogating the system.

Load & Speed Detection

Load cell and belt speed sensor inputs can handle a broad range of devices. Up to eight loadcells in parallel can be handled, with outputs ranging from 1 mV/V to 3 mV/V. Belt speed sensors with outputs from 2.5V to 50V can be accepted. Masterweigh 5 can be supplied with any of Web-Tech's range of Belt Scales or Weighbelt feeders. Brochures on the full range of equipment are available from Web-Tech.



WEB-TECH

Masterweigh 5 Electronic Integrator

Technical Specifications

Power Requirements:

240V AC +/- 10% 50/60 Hz
117V AC +/- 10% 50/60 Hz.

Protection: All inputs internally protected

Load Cell Excitation:

10 VDC, up to eight (8) 350 Ohm load cells.

Load Cell Input 0 - 35mV

Tachometer Input:

Input impedance
4.7K Ohms Input voltage range -50V to +50V DC or AC RMS Maximum input frequency = 800Hz Input waveform: Sinusoid or square wave.

Analogue Output:

4/20mA **Rate**; Internal or external supply, optically isolated.

Relay Outputs:

Totaliser output; Voltage free, 5 Volt, or 28 Volt contacts, one pulse per increment of least significant digit shown in the display, 20 mS - 1000 mS mark space ratio, user programmable.

System Status; Active on detection of internal electronic fault. N/O

AutoZero Tracking; Activated on detection of autozero out of range limit being exceeded. N/O

WEB-TECH AUSTRALIA PTY LTD

Head Office - Brisbane:

11 Electronics Street,
Eight Mile Plains Old 4113.

Telephone: (07) 3841 2844 Fax: (07) 3841 0005

Email: webtech@onaustralia.com.au

Web Page www.web-tech.com.au

Postal Address: PO Box 4006,
Eight Mile Plains Qld Australia 4113

Sydney Office: Suite 1/1 Gladstone Road,
Castle Hill NSW 2154

Telephone: (02) 9757 2296 Fax: (02) 9899 6585

Email: webtechsydney@onaustralia.com.au

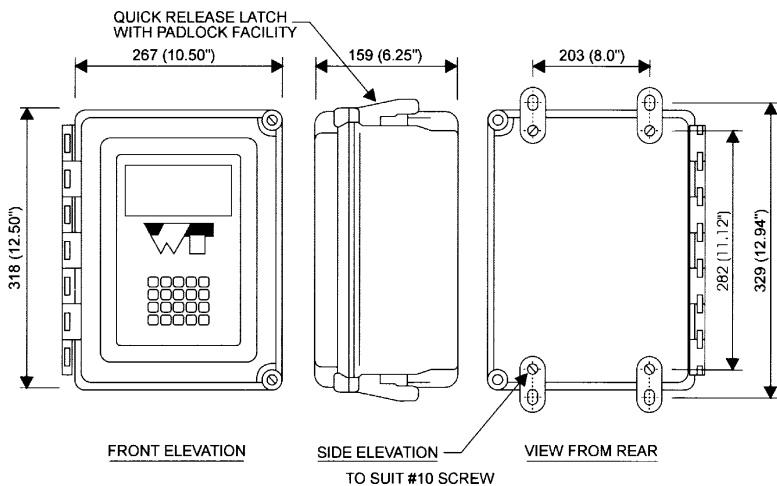

Masterweigh 5 is suitable for use with existing conveyor belt scale scales, weigh feeders or impact weighers that use regular type load cells. Belt speed input has been designed to accommodate most electronic type encoders/tachometers currently available. Contact the factory for additional information regarding retrofitting.

