

Model 401 Level Indicator



The LI401 Digital Indicator, is a microcontroller based instrument providing continuous measurement of material levels within silos and storage vessels for both new and existing applications. The instrument's user interface and indication of material level is displayed via a graphical LCD. The instrument provides an isolated 4-20mA current loop to directly indicate the level of product inside a vessel, two programmable setpoints with mechanical relays to control external devices and a dedicated system healthy relay. The LI401 is designed with optional fieldbus communication plug-in card for protocols such as Ethernet-IP, Modbus-TCP, DeviceNet and Profibus.

Model LI401 Specifications

Enclosure:	IP66 Reinforced Polyester	
Supply Voltage:	85-260 VAC, 24VDC optional	
Load Cell Supply:	10 VDC	
Max No. of Load Cells	8 @ 350 Ω	
Display:	240 x 64 graphic backlit LCD	
Analogue Output:	Isolated 4-20mA	
Setpoints:	Two off, voltage free contacts	
Serial Comms:	Optional Profibus, Ethernet or Devicenet	
Calibration:	Automatic via keypad	
Standard Features:	<ul style="list-style-type: none"> • Auto Zero • Adjustable digital filtering • Programmable access code • Diagnostics menu • Data logging to SD card • USB port for data downloads 	<ul style="list-style-type: none"> • Compact flashcard reader for calibration data storage • System "Healthy" output

Head Office

Web Tech Autoweigh
11 Electronics Street
Eight Mile Plains
Queensland, 4113
Australia

Sydney Office

Web Tech Autoweigh
11/5-7 Anella Avenue
Castle Hill
New South Wales, 2154
Australia

Telephone: +61 7 3841 2844
Toll Free : 1800 777 906
Facsimile : +61 7 3841 0005
Email : info@web-tech.com.au
Website : www.web-tech.com.au



AutoWeigh

Designers and Manufacturers of
Continuous Weighing and Feeding Equipment

LI401 Enclosure Dimensions

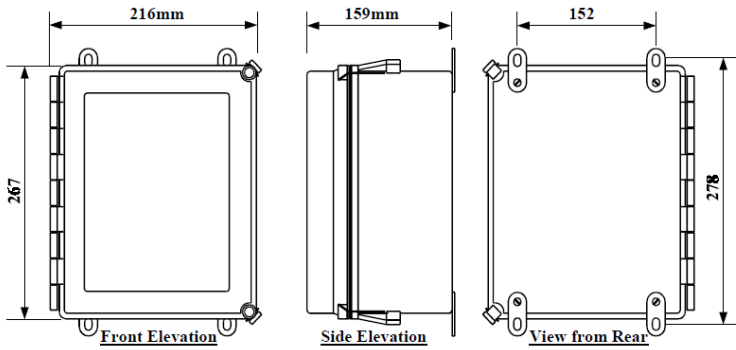

Head Office

Web Tech Autoweigh
11 Electronics Street
Eight Mile Plains
Queensland, 4113
Australia

Sydney Office

Web Tech Autoweigh
11/5-7 Anella Avenue
Castle Hill
New South Wales, 2154
Australia

Telephone: +61 7 3841 2844
Toll Free : 1800 777 906
Facsimile : +61 7 3841 0005
Email : info@web-tech.com.au
Website : www.web-tech.com.au