



## "Optimus Plus" Loss-In-Weight Controller

"Optimus Plus" is an advanced, precision, microprocessor based, bulk solids feeder controller. Its unique design makes it suitable for use with the Web-Tech range of feeders, or as an upgrade controller for most bulk solids feeders that are in current use. Ample input & output facilities combined with a range of industrial communications protocols (DeviceNet & ProfiBus) make Optimus a powerful and versatile instrument. Housed in an industrial enclosure rated to IP66 specification, "Optimus Plus" is suitable for use in the most demanding of industrial environments.

"Optimus Plus" is an enhanced version of the standard "Optimus". Using a grayscale, quarter VGA screen, "Optimus Plus" has been designed for use with vibratory & screw type LIW feeders. The larger display allowing for the presentation of ample amounts of feeder data and alarms.



### Easy Set Up and Calibration

A twenty one key, keypad is used to enter calibration data, as well as to access. Multipurpose function keys provide a method of navigating through the menu structure.

Historical trending is available allowing for process variable examination. All relevant I/O status conditions are viewable at any time, along with the load cell and tachometer outputs in real time. Initial and ongoing calibration data is held in non volatile RAM. An on board flash memory card provides the user with an elegant method of updating system firmware. The flash card also allows for the logging of up to 2 weeks PV, set point, load cell tachometer and various other parameters.

Because calibration procedures are menu driven and prompts are full English statements, adjustments to any parameters are easily accomplished by just a few key strokes.

Data pertaining to any calibration can be recorded automatically by connecting a printer (optional extra) to the RS 232 port and initiating the print menu depending on software installed.

Optional add on cards provide for the use of ProfiBus & DeviceNet protocols.

### Outputs for Remote Counters and Displays

"Optimus Plus" has outputs which allow it to communicate with a wide variety of displays and controls. A 4-20mA current loop provides a proportional rate signal. This signal can be used to drive analogue or digital rate meters or to provide rate data to PLC etc. A second 4-20mA output channel is used to provide the PID signal. This signal can be used to control motor drives to maintain setpoint. Spare digital and analogue inputs can be programmed for various optional signals.

### Standard Features

- Microprocessor based. AMD Elan SC400 microprocessor running at 33, 66 or 100 MHz
- All commands, readings etc. are entered via "thick film keypad".
- Simple Menu driven interface.
- Dot matrix 64 x 240 pixel graphics LCD with digitally adjustable LED backlight brightness and LCD contrast or ¼ VGA (320 x 240 pixel) LCD screen with digitally adjustable CCFL backlighting and screen contrast
- No hieroglyphics are used.
- Local totaliser read out 8 digits wide. Local mass rate read out 6 digits wide.
- Remote totaliser output 24VDC or Voltage Free relay contacts.
- Remote 4-20mA mass rate output.
- Programmable PID - 4-20mA/0-25mA current loop.

# Technical Specifications

## Power Requirements

Standard model is 85-260 VAC, 50/60 Hz. 12/24/48VDC supply models are optionally available.

**Protection:** All inputs internally protected

## Load Cell Excitation:-Unipolar or Bipolar

**Unipolar** - Continuously adjustable from 8.6V -13.4V referenced to ground. Load, 200mA at 10V output, 100mA at 5V output

**Bipolar** - Continuously adjustable from 13.4V - 24V Load, 200mA at 24V output,100mA at 16V output .

## Tachometer Input:

Input impedance 4.7K Ohms Input voltage range -50V to +50V DC or AC RMS Maximum input frequency = 1000 p.p.s Input waveform: Sinusoid or square wave

## Pulse Output:

Transistor output for high speed applications. Maximum switched current - 500mA. 24VDC pulse (internally supplied).

## Analogue Outputs:

“Optimus Plus” provides six (6) channels (two being dedicated to rate & PID control). Remaining channels can be assigned to variables derived by Optimus. Each of the channels can be configured as 4-20mA, or 0-25mA. Each current loop is capable of driving into 1000  $\Omega$  and is optically isolated. Loop output data rate up to 100kHz 12 bit (4096 values) ADC resolution.

## Digital Inputs & Outputs:

Digital inputs and outputs can be voltage free contacts, or 24VDC.

## Enclosure:

Standard enclosure is reinforced fiberglass polyester (RFP). Stainless steel is optionally available.

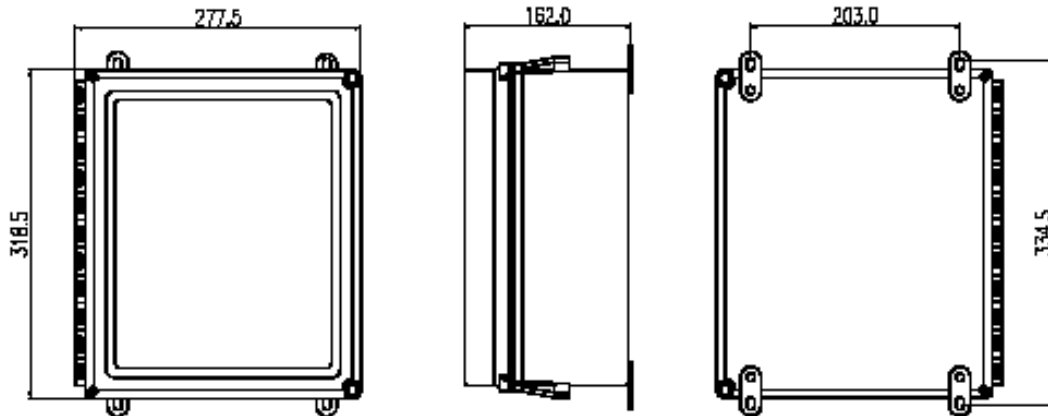

**Web Tech AutoWeigh,**  
11 Electronics Street, PO Box 4006,  
Eight Mile Plains, Brisbane,  
Qld, 4113, Australia

Brisbane (Head office) Ph: (07) 3841-2844,  
Sydney(NSW) / Australia Ph: 1800 777 906  
International Ph: +61 7 3841-2844, Fax + 61 7 3841 0005  
Email: [info@web-tech.com.au](mailto:info@web-tech.com.au) Web Page: [www.web-tech.com.au](http://www.web-tech.com.au)

