

# ***RL50210 TA/65059***

*Load Cell Mounting Kit*

## **Installation Guide**

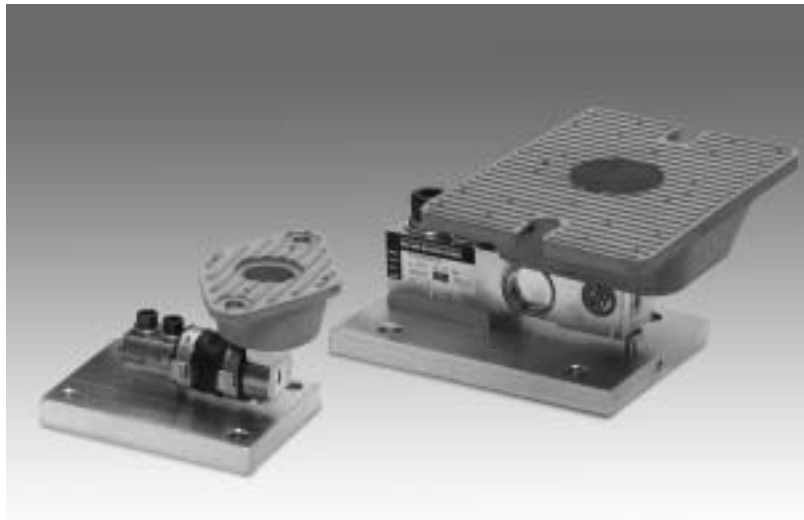

**RICE LAKE WEIGHING SYSTEMS**  
Commitment Beyond Measurement®



25713

# Contents

<b>1. Introduction .....</b>	<b>1</b>
<b>2. Mechanical Installation .....</b>	<b>2</b>
2.1 Installation Guidelines for Compression Weighing Assemblies ...	2
2.2 Installing the RL50210 TA/65059 Mount .....	3
<b>3. Load Cell Wiring .....</b>	<b>6</b>
<b>4. Junction Box Connections, Adjustments &amp; Calibration .....</b>	<b>6</b>
<b>5. Troubleshooting .....</b>	<b>7</b>
<b>6. Maintenance and Replacement Parts .....</b>	<b>8</b>
<b>7. Limited Warranty .....</b>	<b>11</b>

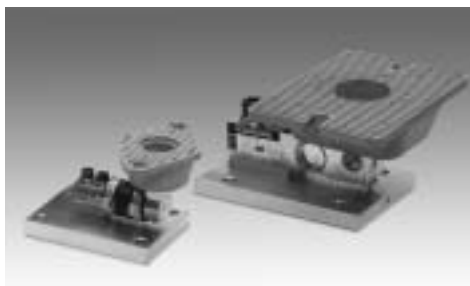

## 1. Introduction

---

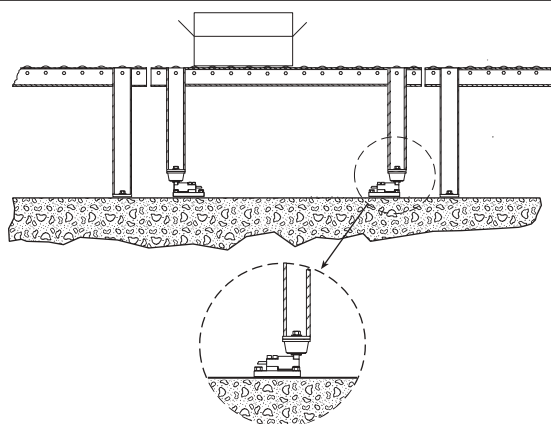

*Typical Mounting Configuration*

Rice Lake Weighing Systems' 50210 TA/65059 Mini-Tank Weighing Assemblies provide an easy-to-use, cost-effective, and reliable method for low capacity weighing applications. They are ideal for installations where checking requirements are low. The flexible neoprene mounting system allows for bolting the units directly to the mounting surface without extra plates or load buttons. The neoprene pad also allows the vessel to expand/contract without restriction and provides a degree of shock protection.

The 50210TA/65059 Mini-Tank Weighing Assemblies are available from 50-250 lb. capacities in zinc-plated or stainless steel versions using cantilever beam load cells. In capacities from 500-2,500 lb., the units use single-ended shear-beam load cells and are available in zinc-plated steel or stainless steel. 1K-2.5K capacities can be fitted with RL35083 or RL35082 stainless steel, welded seal, IP67 load cell. This is a non-part numbered special. Consult factory for quote information.



### **Caution**

The installation should be planned by a qualified structural engineer. Each installation is unique, and this manual is meant to serve only as a general guideline for installation.



Authorized distributors and their employees can view or download this manual from the Rice Lake Weighing Systems distributor site at [www.rlws.com](http://www.rlws.com).

## 2. Mechanical Installation

---

### 2.1 Installation Guidelines for Compression Weighing Assemblies

1. The mounting surface for the base plate and top plate must be level. After installation, the top and bottom plates must be level within  $\pm 0.5^\circ$ . If the mounting surfaces are not level, then shims and/or grout may be used to level the mount.

If possible, check that the mount is level when the vessel is fully loaded because excessive deflections in legs and supporting structures may cause additional side forces which greatly affect accuracy. Deflection of the mount's top or base plate due to loading should not exceed  $\pm 0.5^\circ$ . Reinforcement of legs or support structure may be necessary to correct this. Vessels with long legs should have cross bracing applied between adjacent legs to keep them from spreading under loads.

2. Compression mounting systems use three, four, or more mounts. More than eight mount systems should be avoided as even weight distribution becomes extremely difficult to achieve. The load on each mount assembly should vary no more than 20%. Add shims where necessary to achieve correct load distribution.
3. If the actual load cells are used during installation, extreme care must be taken to prevent overload damage. A tank or hopper weighing several tons can exert huge forces when dropped only a fraction of an inch. Dummy load cells can be used during installation.
4. The neoprene mount of the RL50210 TA/65059 compresses as load is applied, making the mount particularly suitable for applications involving minor shock loading. However, it is not recommended for vessels with attached piping because the added downward deflection of the vessel as it is loaded makes it difficult to design a piping system with the required degree of flexibility.
5. Load cells should not be installed in the mounts until all welding is completed. The heat generated by welding current passing through a load cell can damage the adhesive holding the strain gauge to the body. If possible, use a dummy load cell when welding to maintain finished height. If welding is unavoidable after load cell installation, connect the ground in such a way that the current does not flow through the load cell. For example, if welding on the mount top plate, the ground must be connected to the vessel, not to the mount base or support structure. Also, protect the load cell and cable from weld splatter.

**Note:** The arrow on the load cell should point in the direction of the load.

6. Use only “hermetically sealed” load cells in washdown applications. “Environmentally protected” load cells are not suitable for such applications and will be damaged. If tanks and surrounding equipment are frequently steam cleaned, or if the load cell is subjected to direct washdown, a protective shroud for the weighing assembly is recommended. Proper drainage is necessary so the weighing assembly is not standing in water.
7. All support points should be equally stiff so that they deflect by the same amount as the vessel is loaded.

## 2.2 Installing the RL50210 TA/65059 Mount

The RL50210 TA/65059 load cell mount installation instructions are presented in the following paragraphs. Shown in the figure below are typical load cell mount installations for the 50-250 and 500 lb. configurations.

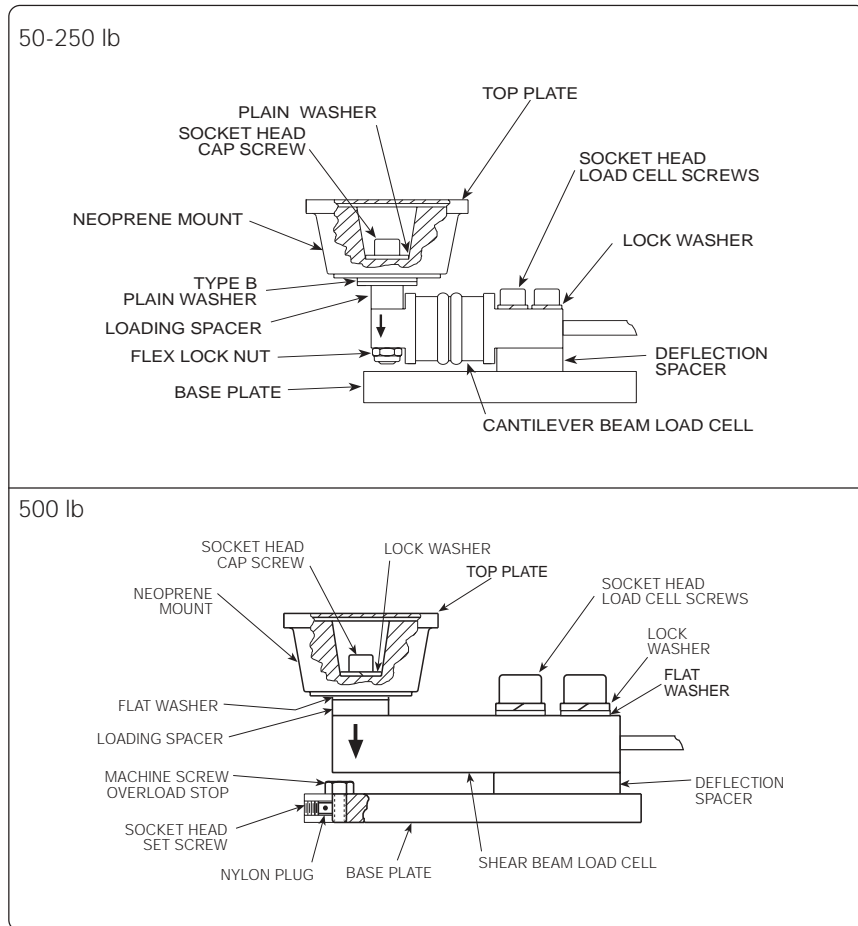

The type of installation, vessel support structure, and the surface upon which the mount is to be placed determines the method of locating, attaching, and assembling the RL50210TA/65059 Mounting Assembly. Carefully consider the following three areas that commonly cause accuracy problems:

- Are the supporting legs adequately braced so they will not spread when the system is fully loaded?
- Does the supporting structure have the necessary strength to prevent excessive deflection when the system is fully loaded?
- Is there attached equipment such as skirting, venting, or piping which is likely to cause binding or lack of flexibility?

After considering any areas that may cause accuracy problems, follow these installation steps.

1. Determine where to position the mount and in which direction it should be oriented. The preferred mounting orientation for single ended beams is with the longitudinal axis of the load cell pointing toward the center of the vessel in circular mounting configurations as illustrated in Figures 1 and 2.

Figures 3 and 4 illustrate mounting configurations for square and rectangular vessels. For rectangular vessels, the load cell's longitudinal axis should be aligned along the vessel's longest dimension as shown in Figure 4. In any application where a recurring side force is present in one direction, such as in a conveyor belt or roller platform, the longitudinal axis of the load cell should align with that force.

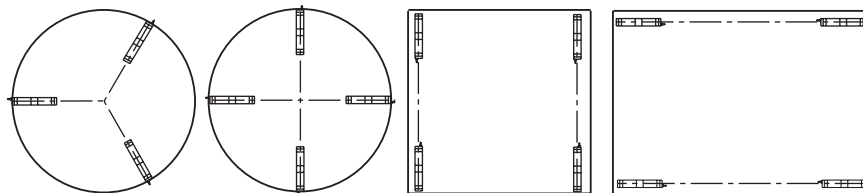

Figure 1

Figure 2

Figure 3

Figure 4

2. Lift and block the vessel to the same height as the assembled mounts.
3. Remove the block from one support point and slide a mount into position.
4. If the mount is being fitted under the leg of a vessel, verify that the center line of the leg passes through the center of the neoprene mount (through the center of the load cell's load hole).
5. Attach the top plate of the neoprene mount by bolting. Do not fully tighten as shimming may be necessary to level.

6. Repeat Steps 4, 5, and 6 for the remaining mounts. The vessel should now be supported on the mounts alone.
7. If necessary, move the vessel to its final position. Verify that there is no initial misalignment between the base plate and top plate by lifting the vessel slightly at each support point in turn. This will also indicate if the load is evenly distributed on all mounts. Shim if necessary.
8. Attach the base plates to the foundation using anchors for concrete or by bolting or welding to a steel structure. Verify that the base plates are no more than  $\pm 0.5^\circ$  out of level. Shim as necessary.
9. Check that the top plates are no more than  $\pm 0.5^\circ$  out of level. Shim if necessary and fully tighten the bolts.
10. The load distribution can be checked more accurately by exciting each load cell and measuring the output with a voltmeter. The variation in load among the cells should be no more than 20%. Shim if necessary.
11. Check that the two screws securing the load cell to the base plate are tight. The torque values are listed in the following table.

Load Cell Capacity (lb)	Recommended Torque (ft-lb)
50 – 250	12
500 – 2500	70

### 3. Load Cell Wiring

1. Route the load cell cables so they will not be damaged or cut. Cable should not be routed near heat sources greater than 150 °F. **Do not shorten any load cell cable.** The load cell is temperature compensated with the supplied length of cable. Cutting the cable will affect temperature compensation. Coil excess cable and protect it so it will not be mechanically damaged or be sitting in water.
2. Provide a drip loop in all cables so that water or other liquids will not run directly down the cables onto either the load cells or the junction box. Attach load cell cable to the dead structure, not the vessel.
3. If conduit protection is necessary against mechanical or rodent damage to the load cell cables, use flexible conduit and conduit adapters at the load cells.
4. Connect cables for RL50210, RL30000, RL50210SS, RL35023S, 60040, 65023, and 65023S load cells to the summing board in the junction box according to the guide shown below and the labels on the terminal strips of the junction box. To verify the wiring scheme, see the certification shipped with the load cell.
5. For better performance, use positive and negative remote sense lines if the wiring run from the junction box to the indicator is longer than 25 feet.

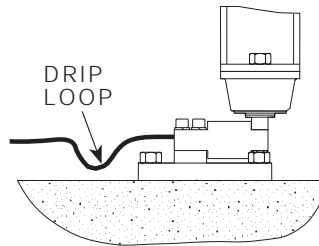

LOAD CELL WIRE COLOR	FUNCTION
Red	+EXC
Black	-EXC
Green	+SIG
White	-SIG
Gray or Bare	SHIELD

### 4. Junction Box Connections, Adjustments & Calibration

- Refer to junction box manual for trimming details.
- Refer to the indicator manual for system calibration guidelines.



## 5. Troubleshooting

If the system powers up and gives some type of stable digital readout that varies with the load on the system, the system problems are probably caused by factors other than the load cells. All too often, the load cells are blamed for a malfunctioning system; 90% of the time, the problem lies elsewhere. Look for mechanical causes for your problem first.

If the system can be calibrated but doesn't return to zero, loses calibration, or demonstrates non-linearity or non-repeatability, see the following chart for possible causes and refer to the following list of checks.

Symptom	Possible Cause
No return to zero	Mechanical binding or debris in seals or under load cells; may have lost system calibration
Non-linearity	Thermal expansion or deflection under load causing binding or side load
Non-repeatability	Loose load cell mount; drifting caused by moisture, load cell overload or shock damage; mechanical binding
Lost calibration	Out of level or plumb; moisture problem; mechanical binding
Drifting readout	Moisture in junction box, cables, or load cell; mechanical binding

1. Check load cell mount for debris restricting load cell movement or debris between scale and structure. Check any overload stops for proper clearance.
2. Check that tank/vessel and mounts are plumb, level, and square at the critical areas.
3. Check all piping and conduit for connections which restrict vessel movement.
4. If check rods are used, loosen all connections to finger tight only for testing.
5. Check load cell cables for physical or water damage.
6. Check all electrical connections, especially in the junction box.

If the problem still is not found:

7. Check possible indicator malfunction by using a load cell simulator to input a known good signal into the indicator.
8. Disconnect each load cell's signal leads at the junction box and check individual load cell outputs with a multimeter. Then check input/output impedances for comparison with load cell manufacturer's specifications.

If after all these checks the problem still cannot be isolated, reconnect all but one load cell. Replace the load cell with a load cell simulator. Alternate so that each load cell is individually disconnected and replaced with a simulator. If there is a problem with a particular load cell, the symptom should disappear when that load cell is disconnected and replaced with the simulator.

## 6. Maintenance and Replacement Parts

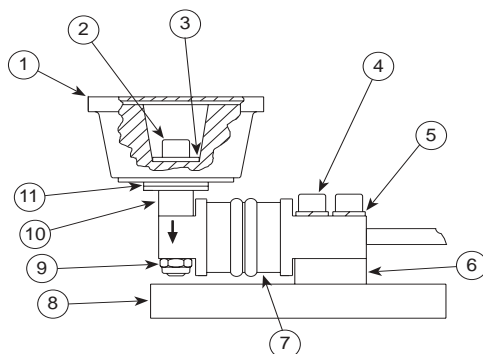

### MILD STEEL RL50210TA/65059 50-250 LB. CAPACITY

No.	Description	Qty.	Replacement Part Numbers			
			50 lb.	100 lb.	150 lb.	250 lb.
1	Vibration Mount	1	18255	18256	18245	18257
2	Socket Head Cap Screw	1	14983	14983	14983	14983
3	Plain Washer	1	21940	21940	21940	21940
4	Socket Hd. Load Cell Screws	2	14982	14982	14982	14982
5	1/4" Lock Washer	2	15147	15147	15147	15147
6	Deflection Spacer	1	18241	18241	18241	18241
7	Cantilever Beam Load Cell	1	<i>See Load Cell Guide</i>			
8	Base Plate	1	18247	18247	18247	18247
9	Flex Lock Nut	1	14643	14643	14643	14643
10	Loading Spacer	1	18240	18240	18240	18240
11	1/4" Type B Plain Washer	3	22011	22011	22011	22011

### STAINLESS STEEL RL50210TA/65059 50-250 LB. CAPACITY

No.	Description	Qty.	Replacement Part Numbers			
			50 lb.	100 lb.	150 lb.	250 lb.
1	Vibration Mount	1	18255	18256	18245	18257
2	Socket Head Cap Screw	1	63790	63790	63790	63790
3	Plain Washer	1	63791	63791	63791	63791
4	Socket Hd. Load Cell Screws	2	63789	63789	63789	63789
5	1/4" Lock Washer	2	15148	15148	15148	15148
6	Deflection Spacer	1	63794	63794	63794	63794
7	Cantilever Beam Load Cell	1	<i>See Load Cell Guide</i>			
8	Base Plate	1	63795	63795	63795	63795
9	Flex Lock Nut	1	63788	63788	63788	63788
10	Loading Spacer	1	63793	63793	63793	63793
11	1/4" Type B Plain Washer	3	63792	63792	63792	63792

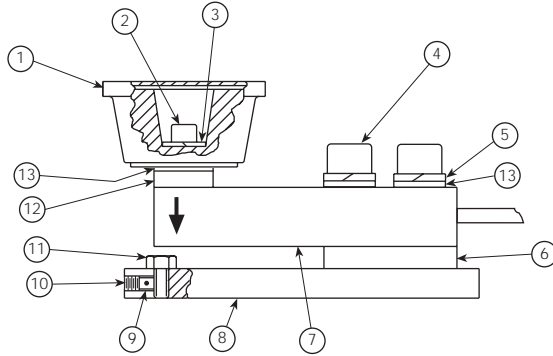

**MILD STEEL RL50210TA/65059 500 LB. CAPACITY**

No.	Description	Qty.	Replacement Part Numbers	
			RL50210	65059
1	Vibration Mount	1	18244	18244
2	Socket Head Cap Screw	1	32185	32185
3	Lock Washer	1	15167	15167
4	Socket Hd. Load Cell Bolts	2	15069	15069
5	1/2" Lock Washer	2	15167	15167
6	Deflection Spacer	1	17754	18260
7	Shear Beam Load Cell	1	<i>See Load Cell Guide</i>	
8	Base Plate	1	18248	18248
9	Nylon Plug	1	18246	18246
10	Socket Head Set Screw	1	14949	14949
11	Mach. Screw Overld. Stop	1	14886	14886
12	Loading Spacer	1	18259	18239
13	1/2" Flat Washer	3	15173	15173

**STAINLESS STEEL RL50210TA/65059 500 LB. CAPACITY**

No.	Description	Qty.	Replacement Part Numbers	
			RL50210	65059
1	Vibration Mount	1	18244	18244
2	Socket Head Cap Screw	1	32280	32280
3	Lock Washer	1	15168	15168
4	Socket Hd. Load Cell Bolts	2	15065	15065
5	1/2" Lock Washer	2	15168	15168
6	Deflection Spacer	1	18411	18383
7	Shear Beam Load Cell	1	<i>See Load Cell Guide</i>	
8	Base Plate	1	18382	18382
9	Nylon Plug	1	18246	18246
10	Socket Head Set Screw	1	14950	14950
11	Mach. Screw Overld. Stop	1	14887	14887
12	Loading Spacer	1	18410	18381
13	1/2" Flat Washer	3	15170	15170

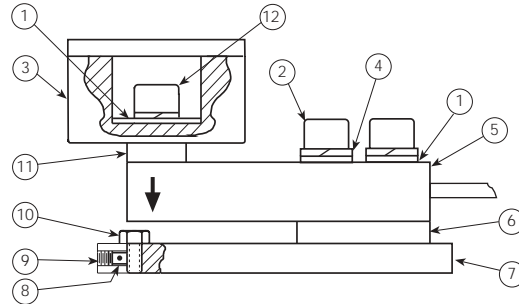

**MILD STEEL RL50210TA/65059 1,000 LB. - 2,500 LB. CAPACITY**

No.	Description	Qty.	Replacement Part Numbers		
			1,000 lb.	2,000 lb.	2,500 lb.
1	1/2" Flat Washer	3	15173	15173	15173
2	Socket Head Cap Screw	2	15076	15076	15076
3	Neoprene Mount	1	18258	26819	26819
4	1/2" Lock Washer	3	15167	15167	15167
5	Shear Beam Load Cell	1	<i>See Load Cell Guide</i>		
6	Deflection Spacer	1	18260	18260	18260
7	Base Plate	1	18248	18248	18248
8	Nylon Plug	1	18246	18246	18246
9	Socket Head Set Screw	1	14949	14949	14949
10	Mach. Screw Overld. Stop	1	14886	14886	14886
11	Loading Spacer	1	18239	18239	18239
12	Socket Head Cap Screw	1	15076	15069	15069

**STAINLESS STEEL RL50210TA/65059 1,000 LB. - 2,500 LB. CAPACITY**

No.	Description	Qty.	Replacement Part Numbers		
			1,000 lb.	2,000 lb.	2,500 lb.
1	1/2" Flat Washer	3	15170	15170	15170
2	Socket Head Cap Screw	2	15077	15077	15077
3	Neoprene Mount	1	18258	26819	26819
4	1/2" Lock Washer	3	15168	15168	15168
5	Shear Beam Load Cell	1	<i>See Load Cell Guide</i>		
6	Deflection Spacer	1	18383	18383	18383
7	Base Plate	1	18382	18382	18382
8	Nylon Plug	1	18246	18246	18246
9	Socket Head Set Screw	1	14950	14950	14950
10	Mach. Screw Overld. Stop	1	14887	14887	14887
11	Loading Spacer	1	18381	18381	18381
12	Socket Head Cap Screw	1	15077	15065	15065

## 7. Limited Warranty

---

Rice Lake Weighing Systems (RLWS) warrants that all RLWS equipment and systems properly installed by a Distributor or Original Equipment Manufacturer (OEM) will operate per written specifications as confirmed by the Distributor/OEM and accepted by RLWS. All weigh modules are warranted against defects in materials and workmanship for two (2) years.

RLWS warrants that the equipment sold hereunder will conform to the current written specifications authorized by RLWS. RLWS warrants the equipment against faulty workmanship and defective materials. If any equipment fails to conform to these warranties, RLWS will, at its option, repair or replace such goods returned within the warranty period subject to the following conditions:

- Upon discovery by Buyer of such non-conformity, RLWS will be given prompt written notice with a detailed explanation of the alleged deficiencies.
- Individual electronic components returned to RLWS for warranty purposes must be packaged to prevent electrostatic discharge (ESD) damage in shipment. Packaging requirements are listed in a publication, "Protecting Your Components From Static Damage in Shipment," available from RLWS Equipment Return Department.
- Examination of such equipment by RLWS confirms that the non-conformity actually exists, and was not caused by accident, misuse, neglect, alteration, improper installation, improper repair or improper testing; RLWS shall be the sole judge of all alleged non-conformities.
- Such equipment has not been modified, altered, or changed by any person other than RLWS or its duly authorized repair agents.
- RLWS will have a reasonable time to repair or replace the defective equipment. Buyer is responsible for shipping charges both ways.
- In no event will RLWS be responsible for travel time or on-location repairs, including assembly or disassembly of equipment, nor will RLWS be liable for the cost of any repairs made by others.

THESE WARRANTIES EXCLUDE ALL OTHER WARRANTIES, EXPRESSED OR IMPLIED, INCLUDING WITHOUT LIMITATION WARRANTIES OF MERCHANTABILITY OR FITNESS FOR A PARTICULAR PURPOSE. NEITHER RLWS NOR DISTRIBUTOR WILL, IN ANY EVENT, BE LIABLE FOR INCIDENTAL OR CONSEQUENTIAL DAMAGES.

RLWS AND BUYER AGREE THAT RLWS'S SOLE AND EXCLUSIVE LIABILITY HEREUNDER IS LIMITED TO REPAIR OR REPLACEMENT OF SUCH GOODS. IN ACCEPTING THIS WARRANTY, THE BUYER WAIVES ANY AND ALL OTHER CLAIMS TO WARRANTY.

SHOULD THE SELLER BE OTHER THAN RLWS, THE BUYER AGREES TO LOOK ONLY TO THE SELLER FOR WARRANTY CLAIMS.

No terms, conditions, understanding, or agreements purporting to modify the terms of this warranty shall have any legal effect unless made in writing and signed by a corporate officer of RLWS and the Buyer.

© 2004 Rice Lake Weighing Systems, Inc. Rice Lake, WI USA. All Rights Reserved.

**RICE LAKE WEIGHING SYSTEMS • 230 WEST COLEMAN STREET  
RICE LAKE, WISCONSIN 54868 • USA**