

RL9000 TWM

Load Cell Mount

Installation Guide

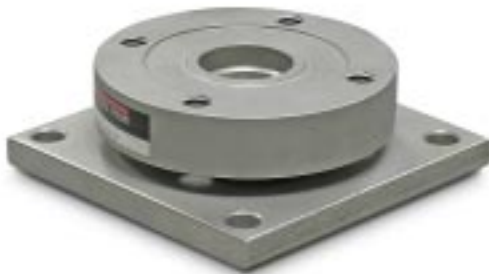

Contents

1. Introduction	1
2. Mechanical Installation	2
2.1 General Installation Guidelines for Tank Mounts	2
2.2 Installing the RL9000TWM	3
3. Load Cell Wiring	5
4. Junction Box Connections, Adjustments & Calibration	6
5. Troubleshooting	6
6. Dimensional Drawings	7
7. RL9000 TWM Limited Warranty	9

1. Introduction

The RL9000 TWM Load Cell Mount provides an extremely accurate method for weighing medium and large capacity tanks and hoppers that are subject to large thermal expansion/contraction or vibration forces. The design uses a low profile shear web load cell (350Ω bridge) and transmits the load via a spherical washer on the load-bearing hub of the cell. This design is very effective in providing for thermal expansion/contraction with little friction.

In most applications, the assemblies are self-checking and held captive with no need for check or stay rods, making this mount a good choice for most vessel weighing applications. The shear web design eases load cell installation and replacement without the need to raise the weighed vessel a large amount, which could disturb piping and other connections.

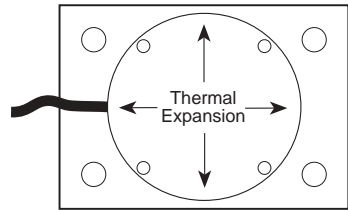

The RL9000 TWM is available in stainless steel, in capacity sizes from 1,000-450,000 lb. The RL9000 TWM utilizes a welded-seal stainless steel load cell.

The installation should be planned by a qualified structural engineer. Each installation is unique, and this manual is meant to serve only as a general guideline for installation.

The RL9000 TWM is capable of weighing accurately with as much as a 3° non-parallel loading. The RL9000 TWM module offers 100% sideload, 100% uplift and 300% overload protection.



Authorized distributors and their employees can view or download this manual from the Rice Lake Weighing Systems distributor site at www.rlws.com.

2. Mechanical Installation

2.1 General Installation Guidelines for Tank Mounts

1. The mounting surface for base and top plate must be level. After installation, the top and bottom plates must be level within $\pm 0.5^\circ$. If the mounting surfaces are not level, then shims and or grout may be used to level the mount.

If possible, check that the mount is level when the vessel is fully loaded because excessive deflections in legs and supporting structures may cause additional side forces which greatly affect accuracy. Deflection of the mount's top or base plate due to loading should not exceed $\pm 0.5^\circ$. Reinforcement of legs or other support structures may be necessary to correct this. Vessels with long legs should have cross bracing applied between adjacent legs to keep them from spreading under load.

2. Compression mounting systems use three, four, or more mounts. More than eight-mount systems should be avoided as even weight distribution becomes extremely difficult to achieve. The load on each mount assembly should vary by no more than 20%. Add shims where necessary to achieve correct load distribution.
3. Take extreme care to prevent overload damage. A tank or hopper can exert huge forces when dropped only a fraction of an inch.

4. It is crucial that all piping or conduit be horizontal and flexible. If flexible piping is not used, make sure distance from vessel to the first pipe support is 20-30 times pipe diameter. In smaller, lower capacity tanks and hoppers, isolating resultant forces becomes extremely critical. For details, see our *Weigh Modules & Vessel Weighing Systems* manual, P/N 43918.

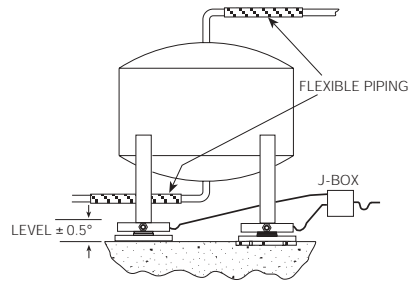

5. The weighing assemblies should not be installed until all welding is completed. The heat generated from welding current passing through a load cell can damage the adhesive holding the strain gauge to the body. If possible, use a dummy mount when welding to maintain finished height. If welding is unavoidable after load cell installation, connect the ground in such a way that the current does not flow through the load cell. For example, if welding on the mount top plate, the ground must be connected to the vessel, not to the mount base or support structure. Also, protect the load cell and cable from weld splatter.
6. Use only "hermetically sealed" load cells in washdown applications. "Environmentally protected" load cells are not suitable for such applications and will be damaged. If tanks and surrounding equipment are frequently steam cleaned or if the load cell is subjected to direct washdown, a protective shroud for the weighing assembly is recommended. Proper drainage is necessary so the weighing assembly is not standing in water.
7. All support points should be equally stiff so that they deflect by the same amount as the vessel is loaded.

2.2 Installing the RL9000 TWM

1. The type of installation and strength of the mounting surface governs the method of locating, attaching, and installing the RL9000 TWM assembly. Carefully consider three areas which commonly cause accuracy problems:
 - Are the supporting legs adequately braced so they will not spread when the system is fully loaded?
 - Does the supporting structure have the necessary strength to prevent excessive deflection when the system is fully loaded?
 - Is there attached equipment such as skirting, venting, or piping which is likely to cause binding or lack of flexibility?
2. Determine where to position each mount. The RL9000 TWM is designed to allow for lateral movement in any direction. Sample mounting orientations to accommodate different vessel shapes are as follows:

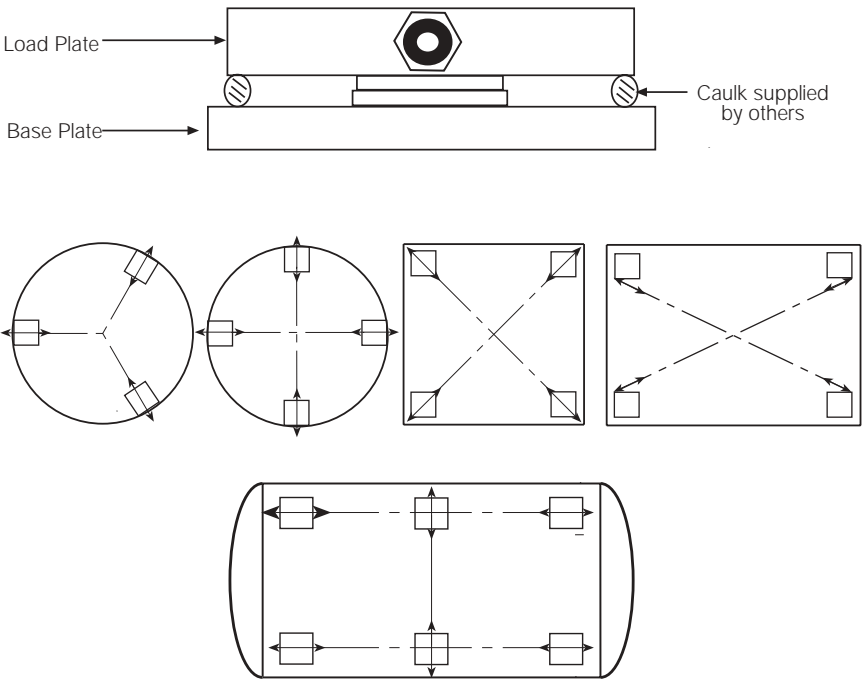

3. Make necessary preparations to the mounting surfaces. A 1" sub plate can be used to ensure a good mounting surface.
4. Lift and block the vessel to the same height as the assembled mounts. Slide mount into position.
5. If the mount is being fitted under the leg of a vessel, verify that the leg's center line passes through the center of the top plate (through the center of the load cell).

6. Lower the corner or side of the vessel carefully onto the top plate. The force of a vessel weighing several tons can damage a load cell if dropped only a fraction of an inch.
7. With the top plate positioned approximately level, mark holes for attaching the top plate to the vessel's mounting surface. Drill holes and attach top plate loosely to vessel with suitable fasteners.
8. Repeat steps 4-10 for the mounting assemblies at the remaining corners or sides.
9. Verify that there is no initial misalignment between the base plate and top plate.
10. Attach the base plates to the foundation using suitable anchors for concrete or by bolting or welding to a steel structure or subplate. Verify that the base plates are as level as possible. They should be fully supported. Shimming is not recommended.
11. Check that the top plates are no more than $\pm .5^\circ$ out or level. Shim if necessary and fully tighten mounting bolts.
12. To achieve equal load distribution, final height adjustments can be made with shims between the top plate loading bracket and the weighing vessel. The variation in load among the cells should be no more than 20%. The load distribution can be checked accurately by exciting each load cell in turn and measuring the output with a voltmeter.
13. Consider using a bead of flexible caulk between the load cell and the base on lighter capacity assemblies. This will prevent debris from lodging between the load cell and the base and causing repeatability or accuracy problems.
14. The top plate must move freely. The RL9000 TWM come directly from the factory correctly assembled and locktightened and should not require adjustment. If the RL9000 TWM has been disassembled for any reason, perform the following:
 - a. Remove the large center screw
 - b. Align the convex load disc and the load cell with the center hole in the base plate
 - c. Locktight and install the large screw and continue to turn until the rubber o-ring just contacts the convex load disc
 - d. Back the screw off 1/4 turn. The screw provides lateral restraint and lift off protection. Never remove it or back it off more than the suggested amount.

3. Load Cell Wiring

1. Route the load cell cables so they will not be damaged or cut. Cable should not be routed near heat sources greater than 150 °F. **Do not shorten any load cell cable.** The load cell is temperature compensated with the supplied length of cable. Cutting the cable will affect temperature compensation. Coil and protect excess cable so it will not be mechanically damaged or be sitting in water.
2. Provide a drip loop in all cables so that water or other liquids will not run directly down the cables onto either the load cells or the junction box. Attach load cell cable to the dead structure, not the vessel.
3. If conduit protection is necessary against mechanical or rodent damage to the load cell cables, use flexible conduit and conduit adapters at the load cells.
4. Connect cables for load cells to the summing board in the junction box according to the guide shown below and the labels on the terminal strips of the junction box. To verify the wiring scheme, see the certification shipped with each load cell.
5. For better performance, use positive and negative remote sense lines if the wiring running from the junction box to the indicator is longer than 25 feet.

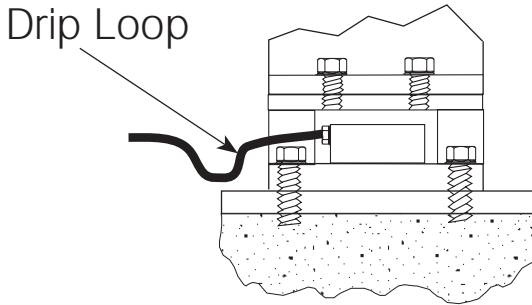

Load Cell Wire Colors	
Wire Color	Function
	Positive Reading
Green	+Exc
Black	-Exc
Red	-Sig
White	+Sig
Gray or Bare	Shield

4. Junction Box Connections, Adjustments & Calibration

1. Refer to junction box manual for trimming details.
2. Refer to indicator manual for system calibration details.

5. Troubleshooting

If the system powers up and gives some type of stable digital readout that varies with the load on the system, any system problems are probably caused by factors other than the load cells. The load cells are often blamed for a malfunctioning system, but 90% of the time, the problem lies elsewhere. Look for mechanical causes for your problem first.

If the system can be calibrated but doesn't return to zero, loses calibration, or demonstrates non-linearity or non-repeatability, see the following chart for possible causes and do the following checks.

Symptom	Possible Cause
No return to zero	Mechanical binding or debris in seals or under load cells; may have lost system calibration
Non-linearity	Thermal expansion or deflection under load causing binding or side load
Non-repeatability	Loose load cell mount; drifting caused by moisture, load cell overload or shock damage; mechanical binding
Lost calibration	Out of level or plumb; moisture problem; mechanical binding
Drifting readout	Moisture in junction box, cables, or load cell; mechanical binding

1. Check load cell mount for debris restricting load cell movement or debris between scale and structure.
2. Check that tank/vessel and mounts are plumb, level, and square at critical areas.
3. Check all piping and conduit for connections which restrict vessel movement.
4. If check rods are used, loosen all connections to finger tight only for testing.
5. Check load cell cables for physical or water damage.
6. Check all electrical connections, especially in the junction box.

If the problem still is not found:

7. Check possible indicator malfunction by using a load cell simulator to input a known good signal into the indicator.
8. Disconnect each load cell's signal leads at the junction box and check individual load cell outputs with a multimeter. Then check input/output impedances for comparison with load cell manufacturer's specifications.

If after all these checks the problem still cannot be isolated, reconnect all but one load cell. Replace load cell with a load cell simulator. Alternate so that each load cell is individually disconnected and replaced with a simulator. If there is a problem with a particular load cell, the symptom should disappear when that load cell is disconnected and replaced with simulator.

6. Dimensional Drawings

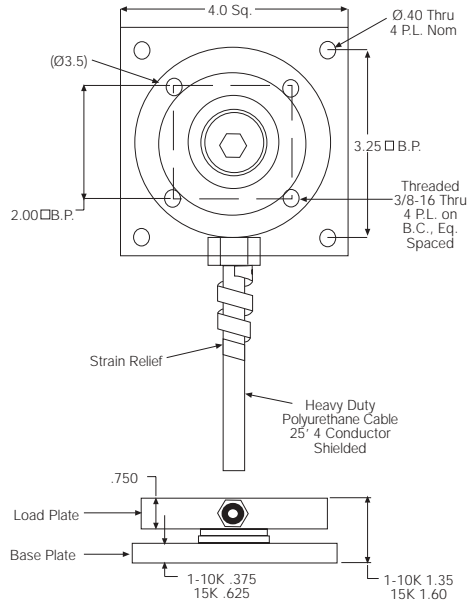

1K to 15K Assembly

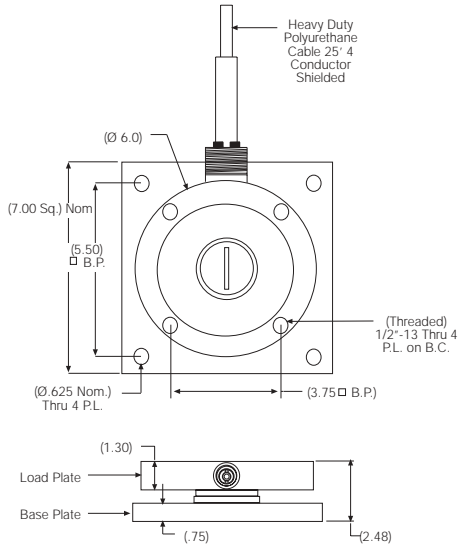

20K to 50K Assembly

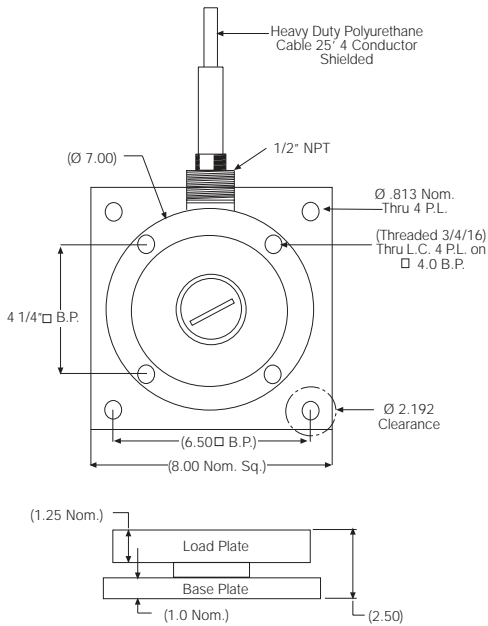

60K to 125K Assembly

7. RL9000 TWM Limited Warranty

Rice Lake Weighing Systems (RLWS) warrants that all RLWS brand load cells properly installed by a Distributor or Original Equipment Manufacturer (OEM) will operate per written specifications. All load cell products are warranted against defects in materials and workmanship for two (2) years. Products marked as “waterproof” are warranted against defects in materials and workmanship relating to moisture ingress.

RLWS warrants that the equipment sold hereunder will conform to the current written specifications authorized by RLWS. RLWS warrants the equipment against faulty workmanship and defective materials. If any equipment fails to conform to these warranties, RLWS will, at its option, repair or replace such goods returned within the warranty period subject to the following conditions:

- Upon discovery by Buyer of such non-conformity, RLWS will be given prompt written notice with a detailed explanation of the alleged deficiencies.
- Examination of such equipment by RLWS confirms that the non-conformity actually exists, and was not caused by accident, misuse, neglect, alteration, improper installation, improper repair or improper testing; RLWS shall be the sole judge of all alleged non-conformities.
- Such equipment has not been modified, altered, or changed by any person other than RLWS or its duly authorized repair agents.
- RLWS will have a reasonable time to repair or replace the defective equipment. Buyer is responsible for shipping charges both ways.
- In no event will RLWS be responsible for travel time or on-location repairs, including assembly or disassembly of equipment, nor will RLWS be liable for the cost of any repairs made by others.

THESE WARRANTIES EXCLUDE ALL OTHER WARRANTIES, EXPRESSED OR IMPLIED, INCLUDING WITHOUT LIMITATION WARRANTIES OF MERCHANTABILITY OR FITNESS FOR A PARTICULAR PURPOSE. NEITHER RLWS NOR DISTRIBUTOR WILL, IN ANY EVENT, BE LIABLE FOR INCIDENTAL OR CONSEQUENTIAL DAMAGES.

RLWS AND BUYER AGREE THAT RLWS’S SOLE AND EXCLUSIVE LIABILITY HEREUNDER IS LIMITED TO REPAIR OR REPLACEMENT OF SUCH GOODS. IN ACCEPTING THIS WARRANTY, THE BUYER WAIVES ANY AND ALL OTHER CLAIMS TO WARRANTY.

SHOULD THE SELLER BE OTHER THAN RLWS, THE BUYER AGREES TO LOOK ONLY TO THE SELLER FOR WARRANTY CLAIMS.

No terms, conditions, understanding, or agreements purporting to modify the terms of this warranty shall have any legal effect unless made in writing and signed by a corporate officer of RLWS and the Buyer.

© 2005 Rice Lake Weighing Systems, Inc. Rice Lake, WI USA. All Rights Reserved.

**RICE LAKE WEIGHING SYSTEMS • 230 WEST COLEMAN STREET
RICE LAKE, WISCONSIN 54868 • USA**